



www.marlite.com
Effective Date 05/31/2020

SmartSeam Installation Instructions

Statements expressed in this technical bulletin are recommendations for the application of Marlite® brand products as outlined and illustrated under normal conditions of installation. The recommendations provided in the bulletin represent our best judgment based on our experience with normal applications. Unless prior approval is obtained in writing from Marlite®, any deviation from these recommended procedures shall be at the sole risk of the installers.

Symmetrix™ with SmartSeam Wall Panels System Components

- Symmetrix™ SmartSeam FRP Wall Panels
- PVC Trim Molding
- Adhesives & Sealants
 - Marlite® C-551 FRP Adhesive (for porous sub wall such as unfinished drywall)
 - Advanced Polymer Adhesive (for non-porous sub wall such as tile)
 - Marlite® C-109 Cartridge Adhesive (for “finger-locked” SmartSeam installations)
 - Marlite® MS-250 Clear Silicone Cartridge Sealant (for use in place of C-109 if preferred.)
 - Marlite® Silicone Sealant (for higher moisture areas)

Required Tools

Track saw (preferably with dust collection system), caulking gun, tape measure, drill, file, hammer, 2” painters tape, jig saw (for cutouts around fittings), mineral spirits, notched adhesive trowel, plumb line/level and horses/supports.

Storage

Do not store Symmetrix™ FRP Panels or adhesives outside and exposed to the weather and its elements. Damage may occur. Panel expansion / contraction issues may occur when cold panels and adhesives are moved to warmer areas for installation. Store panels flat as long as possible so that the ends do not curl. If the fingerlock ends curl or bend it will make installation more difficult.

Preparation and Important Tips

1. Carefully inspect all Symmetrix™ SmartSeam FRP Panels prior to installation. If a panel is defective, notify immediately the Marlite® Service Center or Distributor nearest you. Failure to do so shall be at the sole risk of the installer.
2. After un-banding, allow panels (positioned flat on the ground) and adhesives to properly acclimate to the room environment prior to installation for at least 24 hours.
3. Ensure that the panels are laid flat to avoid any bending on finger lock edges. If panels are not flat, it may make installation more difficult.
4. Begin installation when the room, panels and adhesive are all approximately 70° F.
5. Application is required over a solid backing, such as drywall or plywood. Surface to be covered must be clean, dry, solid, straight and free from drywall dust, bumps, projections, loose plaster, loose paint or any unsealed joint compound wider than 3”. For seams in excess of 3”, apply drywall primer. For installation over existing tile, refer to the section at the end of the instructions.
6. Maintain plumb vertical edges.

7. Do not position panel joints directly over drywall or plywood joints.
8. Cut FRP Panels face down using a track saw.
9. Use C-551 FRP Adhesive only on porous surfaces such as unfinished, untreated drywall or plywood. For non-porous surfaces such as finished drywall, ceramic tile or old FRP Panels, use Titebond® Advanced Polymer Adhesive.
10. At the top of panels leave a 1/16" space in all channels to accommodate panel expansion and contraction.
11. Apply panel to the wall immediately after applying adhesive to the panel back. Once the C-109 is applied, your work time is <5 minutes. So not allow the adhesive to "skin over" before applying to the wall.
12. Be sure to apply panel roller over the entire panel face after each panel is installed to ensure a good bond.

Room Lay-out and PVC Trim Molding Installation

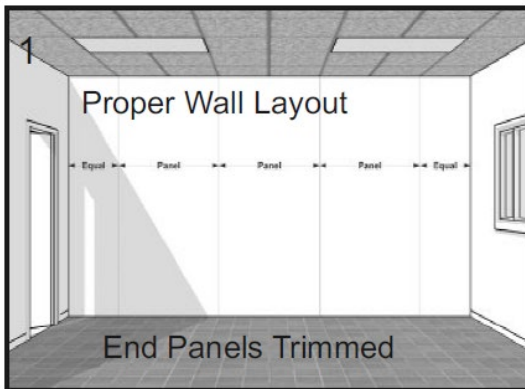

For a balanced appearance, establish a center line of area to be covered and work toward corners. (see illustration 1)

A poor room layout plan may cause very small panels or panel pieces at the end of the wall.

PVC Trim Molding must be applied using pin tacks or staples attached to flange and adhesive. Do not pin tack or staple through Symmetrix™ SmartSeam FRP Panels. **Division molding is not needed with SmartSeam Panels.**

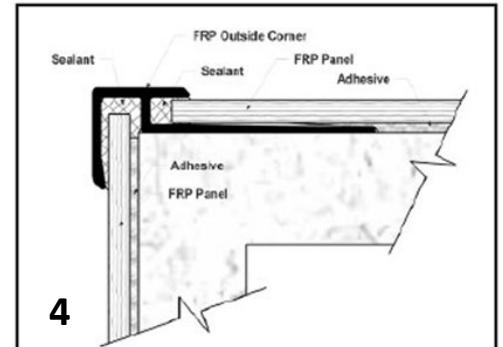
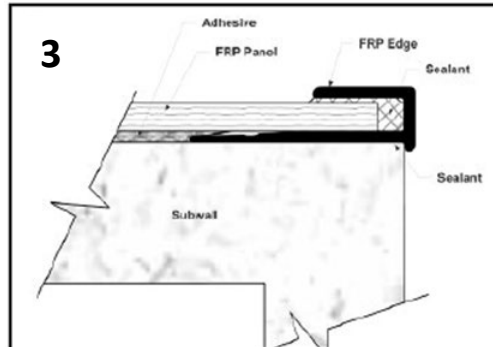
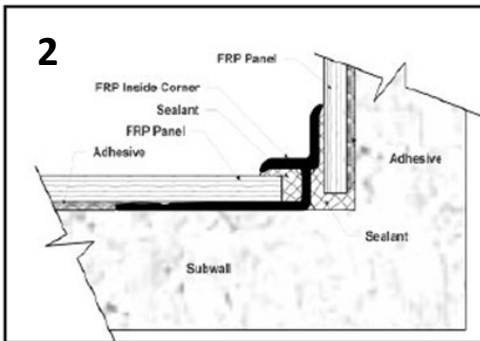

In areas of higher moisture conditions, PVC Trim Molding and FRP Panels must be sealed with Marlite brand Silicone Sealant to ensure a watertight seal. (see illustrations 2-4)

Silicone Sealant is best applied to PVC Trim Molding prior to application to the wall. It is important that a continuous, non-broken bead of sealant is applied. Excess sealant “squeeze-out” should be promptly cleaned off with denatured alcohol. It is suggested that a sealant be applied to all exposed edges of molding, electric plates and other covers after installation. Allow 24 hours drying time for sealant.

Application at Tile Curb, Floor, Base Molding and Ceiling Line

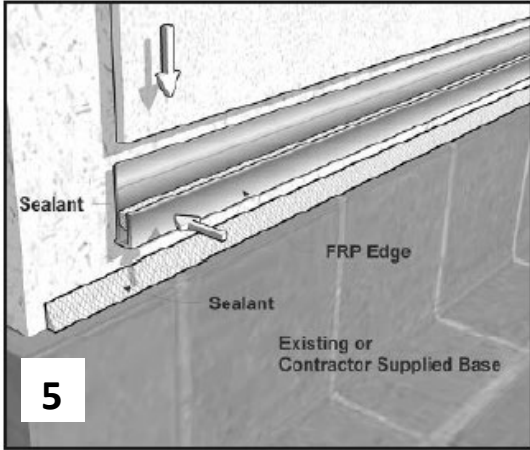

Curb must be installed first. Apply a continuous bead of silicone sealant to the top of curb or floor line and in the PVC Trim Molding channel. Set Edge Trim Molding in place and fasten to the sub wall. Slip FRP Panel into Edge Trim Molding. Allow for 1/8” expansion space and sealant “squeeze-out”. Execute similar application at ceiling line.
(see illustration 5)

Application at Panel Joint

Marlite’s patent pending SmartSeam technology, allows for Symmetrix™ FRP Panels to be butted together without the need for Division PVC Trim Molding or any other joint treatment.

There are 2 types of SmartSeam panels.

1. Fingerlock panels: These panels feature an interlocking design and can be used on a wide range of geometric shapes.
 - a. Starter panel (fig. 1)
 - b. Standard fingerlock panel (fig. 2)
2. Straight beveled edge: These panels are typically stacked square or rectangle patterns that have the patent pending Smartseam groove on all edges to eliminate the need for division molding or silicone seams. (figure 3)

Fingerlock Panels

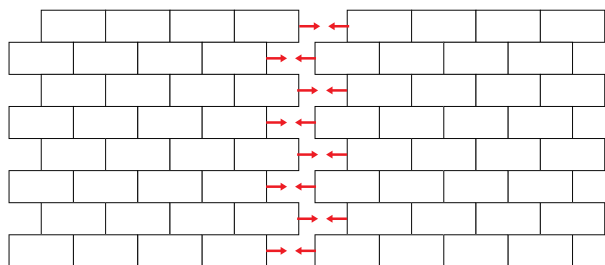
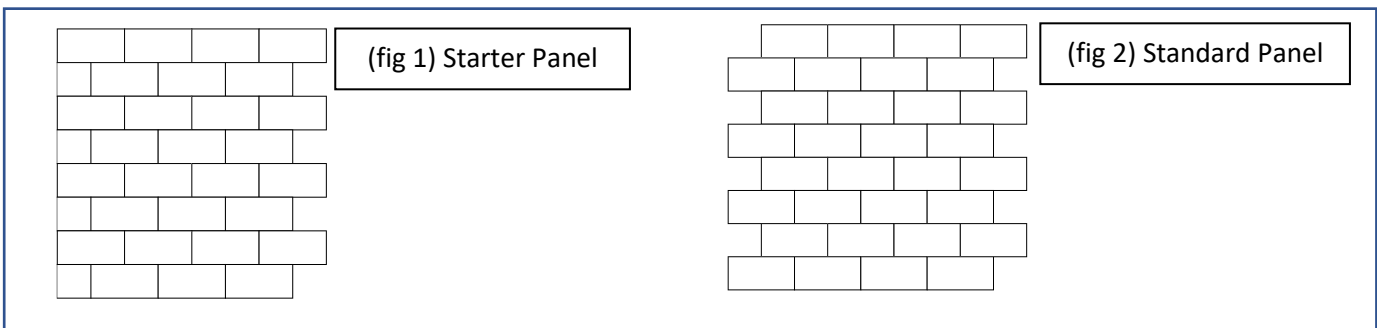

Join panels flush together. No need for a silicone seam joint or division molding.

Straight Edge with Half Groove

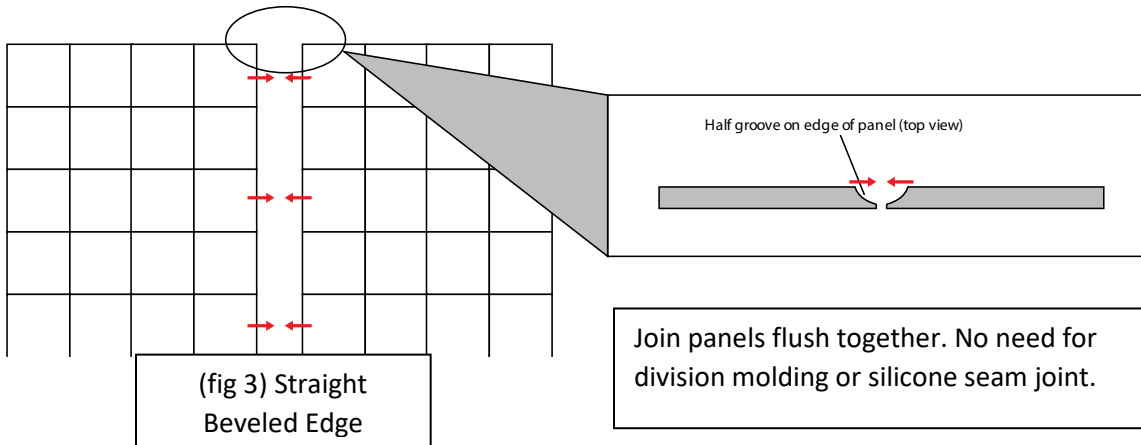

Cutting Symmetrix™ FRP Panels

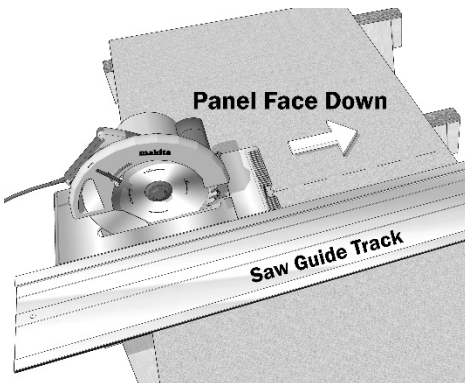

Cut Symmetrix™ FRP Panels face down with a track saw. For cutouts, drill four holes and radius all corner cuts to avoid chipping.

Rough-cut Symmetrix™ SmartSeam FRP Panel edges can be smoothed with sandpaper or a file.

Application of Adhesive

Always apply Marlite® C-551 FRP Adhesive or Advanced Polymer Adhesive to the FRP Panel back. Be sure the existing sub wall is porous, straight, clean, and dry. Apply over plywood or drywall that is void of excessive joint compound. Walls with excessive joint compound wider than 3" should be sealed prior to installation.

Use Marlite® C-551 FRP Adhesive over porous sub walls such as unfinished / untreated drywall or plywood. **For any non-porous surface such as painted drywall, ceramic tile or existing FRP Panels, Advanced Polymer Adhesive is required. For Symmetrix™ FRP SmartSeam Panels with "finger-locked" edges, Marlite® C-109 Cartridge Adhesive is required. Perform a trial to ensure acceptable adhesion and performance.**

Adhesive is easiest to spread at approximately 70°F. **Symmetrix™ FRP Panels must be installed while the adhesive is fresh, within 5 minutes of application.** Adhesive on the panel face should be removed promptly using **mineral spirits**. Adhesive coverage is 210 square feet per 3.5 gallon can.

Apply adhesive to the entire back of the FRP Panel using a notched spreader or trowel. **Trowel size is 3/16" wide x 1/4" deep x 1/2" c-c notch.**

100% coverage over the entire Symmetrix™ FRP Panel back is required except approximately 1" at edges. Use the notches in the spreader to achieve the exact depth of adhesive. The spreader end must be kept at 90° to the panel surface. Avoid too heavy a coat. To assure proper ridges when spreading adhesive, keep notches of the spreader clean (see figure 1-A). Once coverage is achieved, trowel the adhesive in one direction going from top to bottom. (see figure 1-B) **For Fingerlock panels** use cartridge adhesive to create a "swirl" pattern on the end tabs. Do not use trowel on fingerlock tabs. (see figure 1-C) If using Marlite MS-250 Clear Silicone Sealant, make 3 lines that border the edge of the fingerlock tab. (see figure 1-D)

Once panel is adhered to wall, apply pressure by rolling (see figure 1-E). Be sure of 100% adhesive transfers. You will want to use considerable pressure while rolling. This is a very important part of the installation. Pay particular attention to the panel seams. You will want to go back and re-roll the panel you previously installed to ensure no sections of the panel lift away from the wall causing an uneven installation.

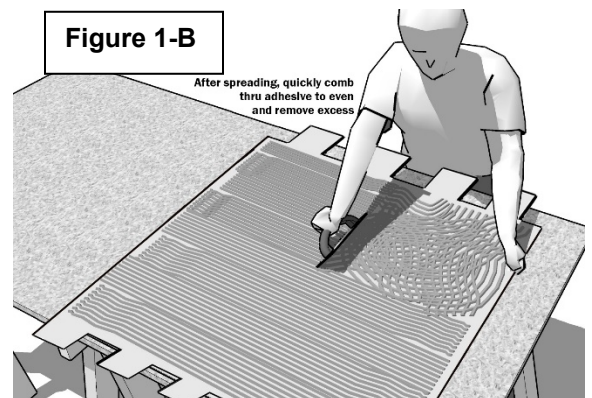
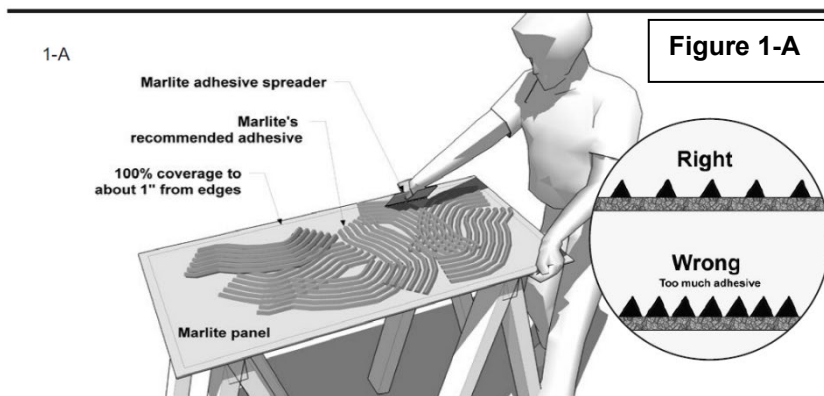

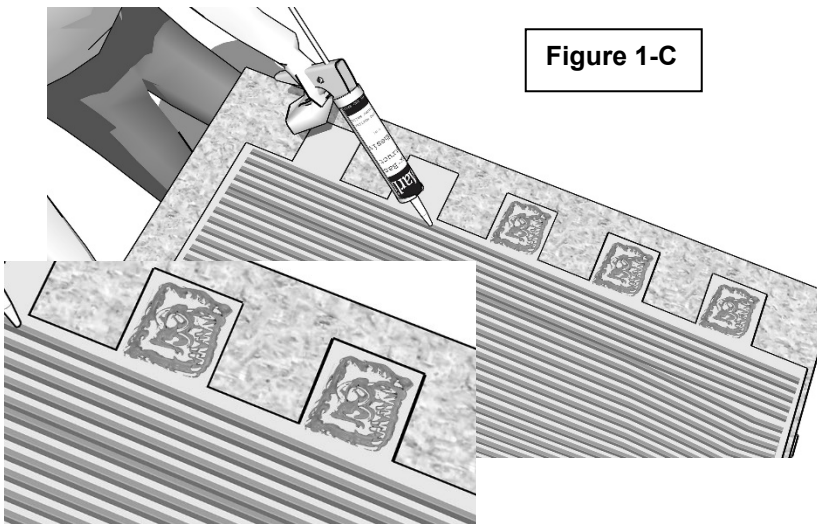

Figure 1-C

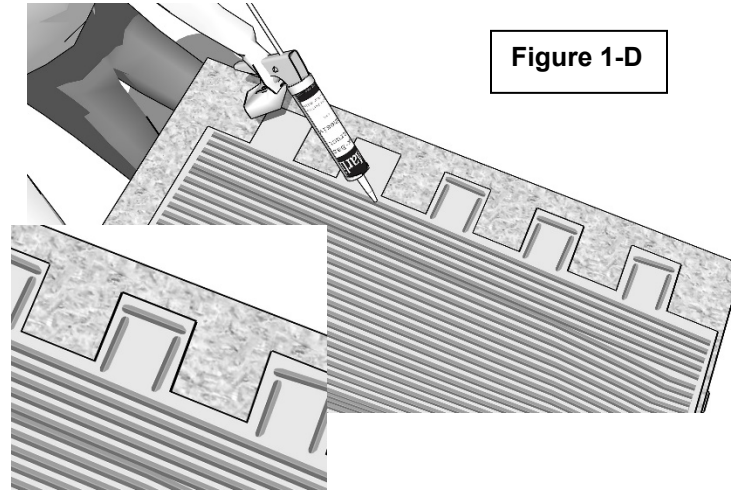

Figure 1-D

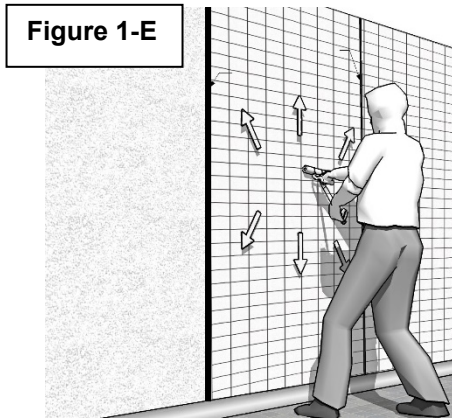

Figure 1-E

FOR INSTALLATION OVER EXISTING CERAMIC TILE

If you are installing Symmetrix directly over existing ceramic tile, there are a few added preparation steps to ensure a proper and easy installation.

1. Scuff the tile thoroughly with 40/60 grit sandpaper.
2. Use denatured alcohol to wipe the surface clean of sanding dust, oil, grease, or other surface contaminants. Any contaminants left on the surface will affect the adhesive's ability to bond properly.
3. When applying Symmetrix SmartSeam panels, try to ensure that the edges of the fingerlock panels do not overlap directly on top of a grout line in the tile.