



PLANK & PANELS Installation Instructions

www.marlite.com

Effective Date: 11/1/2023

Statements expressed in this technical bulletin are recommendations for the application of Marlite brand products as outlined and illustrated under normal conditions of installation. The recommendations provided in the bulletin represent our best judgment based on our experience with normal applications. Unless prior approval is obtained in writing from Marlite, any deviation from these recommended procedures shall be at the sole risk of the installers. Carefully inspect all panels. If a panel is defective, notify the Marlite Service Center or Distributor nearest you at once. Failure to do so shall be at the sole risk of the installer.

Installation Overview

Read all Installation Instructions prior to installing. Marlite Panels are installed similarly to Marlite Plank, except that the Plank contains a tongue and groove vertical edge. **Never mix print/stain dates.** Color will vary from production runs. Be sure that all dates printed on the short end of each carton are identical. Failure to do so shall be at the sole risk of the installer. Any discrepancies must be communicated to the nearest Customer Service Center or Distributor.

Inspection

Carefully inspect all Plank/Panels prior to installation. If Plank/Panels are defective, notify the nearest Customer Service Center or Distributor at once. Failure to do so shall be at the sole risk of the installer. Due to textures, wood grain patterns, materials and manufacturing techniques, some panels may possess minor variations in color consistency, color tone and pattern. These minor variations are not considered defective.

Conditioning and Expansion

Plank/Panels, like all wood products, must avoid exposure to temperature and humidity extremes. To ensure product performance, a temperature range of 60° -80°F and a humidity range of 35-55% must be maintained during installation and product life cycle. Plank/Panels must be given 48 hours to acclimate to room environment, accomplished by laying the Plank/Panels flat around the room.

Special attention must be given when applying molding and trim. A MINIMUM 1/8" SPACING IS REQUIRED IN ALL MOLDING AND TRIM CHANNELS. For higher moisture areas or aggressive cleaning protocols, a bead of silicone sealant in all molding and trim channels is recommended.

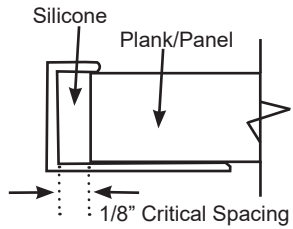

Sub Wall Preparation

The sub wall must have a vapor barrier to prevent any moisture from contacting Plank/Panels. Sub wall must be straight and plumb and be dry, clean and free of any dirt and debris such as drywall dust.

Key Installation Tips

- Installation should begin and end at an inside corner, if possible.
- Plank/Panels shall be cut face down with a circular saw using a fine-toothed carbide blade, or cut face up on a table saw using a fine-toothed carbide blade.
- Plank/Panels are applied using adhesive. **Never nail through Plank/Panels.**
- Install Plank tongue side toward predominate direction of view for best visual effect.

Adhesive Application

Prior to applying adhesive on the back of Plank/Panels, dry-fit them into position. Be sure openings are cut for electrical outlets and plumbing. Pre-plan a balanced lay-out to avoid ending with a narrow width of Plank/Panel in the corner or end-wall.

Plank/Panels are installed using Marlite C-109 Construction Adhesive Cartridges, adhesive is applied in a serpentine pattern (see figure 1). Apply a .25" bead around the entire perimeter and then snake down the panel every 4"-6". 87 lineal feet per 29-ounce cartridge. 43 lineal feet per Plank is recommended.

Marlite Recommends applying Tite-Bond Advanced Polymer Panel Adhesive to the back of each panel. The use of a solvent-based adhesive is strongly recommended. Adhesive is applied to the entire back of each panel, except approximately 1" at edges. Panels must be installed while the adhesive is fresh. The maximum open time for the adhesive is 5 minutes at 70° F. Adhesive coverage is 210 square feet per 3.5 gallon can. DO NOT APPLY ADHESIVE TO THE WALL ONLY. (Adhesive trowel: 3/16" x 1/4" D x 1/2" notch). Keep end of trowel 90° to the Plank/Panel surface.

If using Marlite C-407 Water-based Adhesive (for states with VOC requirements), some warping of Plank/Panels is possible during the first couple hours after installation. Within 72 hours the panels typically flatten and with light pressure applied, the adhesive will permanently secure the panels to the wall.

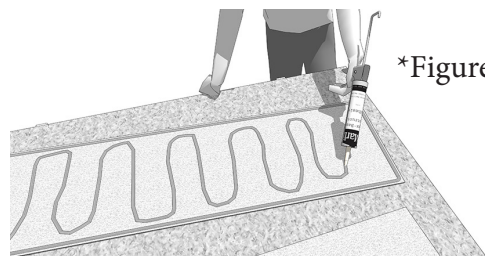

*Figure 1

Adhesive Transfer

It is important to inspect for proper adhesive transfer during the installation of the first few Plank/Panels. Always apply the adhesive to the Plank/Panel back. Adhesive transfer is accomplished by applying the adhesive to the back of the Plank/Panel, pressing the Plank/Panel to the wall (preferably by rolling), then pulling it away from the wall. Strings of adhesive should span between the sub wall and the Plank/Panel.

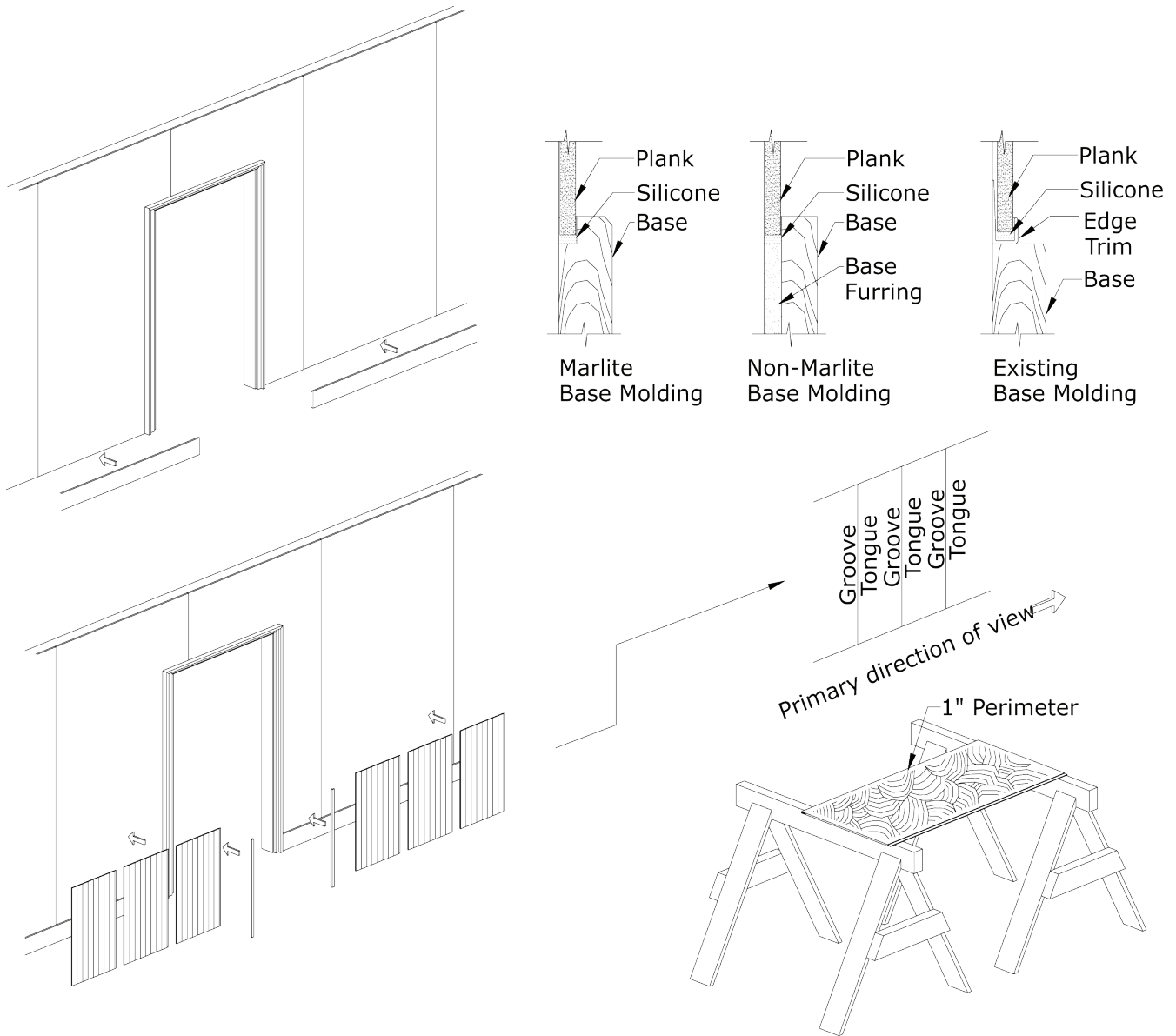

Typical Wall Construction

All framing should be in compliance with local, state and national building codes and regulations and should conform to industry standards of construction.

The sub wall shall be securely fastened to the framing. Appropriate sub wall materials are gypsum wall board and/or plywood. The building shall be completely closed and walls should be straight, thoroughly dry and free of any dirt or drywall dust prior to installing Plank/Panels, molding and trim.

All door casing, window trim and additional accent trim shall be installed prior to Plank/Panel installation.

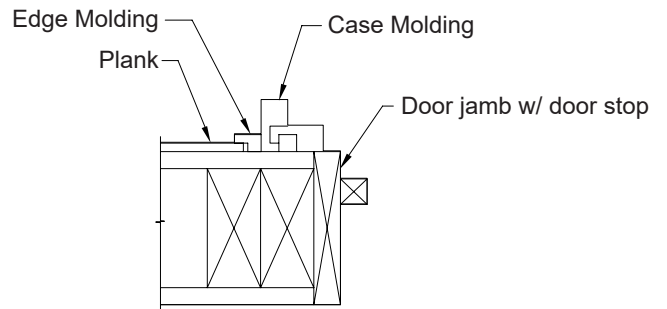
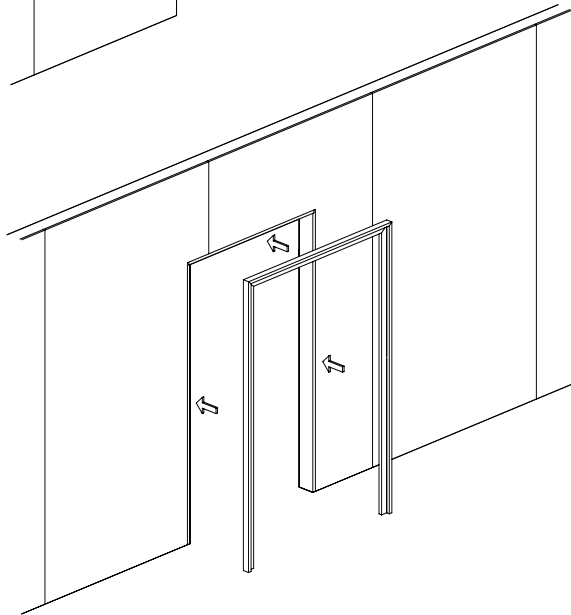
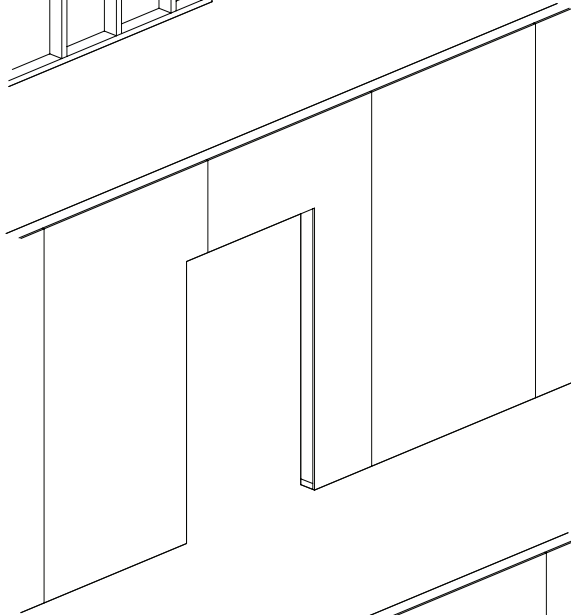
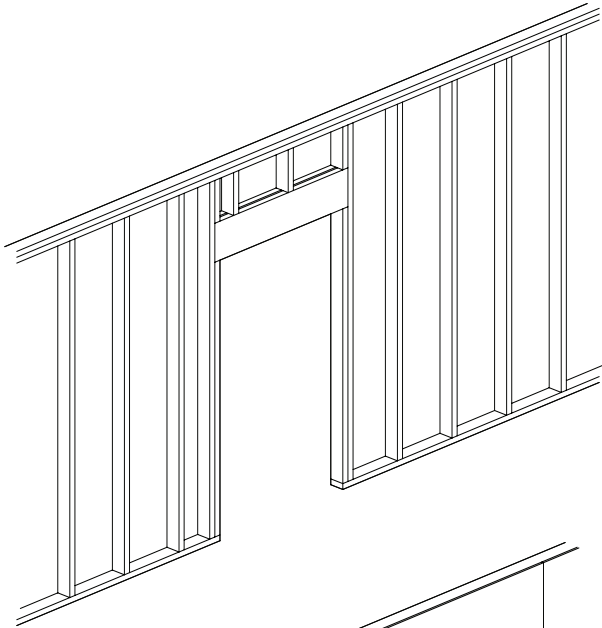

Base Molding Application

Marlite Wood Base Molding shall be installed prior to Plank/Panel application.

Never nail through Plank/Panels.

I/C & O/C Molding Application

When installation has progressed to an outside corner, cut the last piece of Plank/Panel at least 1/8" less than the final measurement. This ensures space for expansion and leaves room for the finishing nail to avoid contact with the Plank/Panel. **Never nail through Plank/Panels.** To remove the excess from the Plank/Panel, cut face down with a circular saw using a fine-toothed carbide blade, or cut face up on a table saw using a fine-toothed carbide blade.

Chair Rail Molding Application

Plank/Panel shall be pre-cut to the desired wainscot height. When applying Marlite Wood Chair Rail Molding, be sure to leave at least 1/8" expansion gap in the channel to insure space for expansion.

Pre-drill all holes when applying Marlite Wood Molding. **Never nail through Marlite Plank/Panels.**

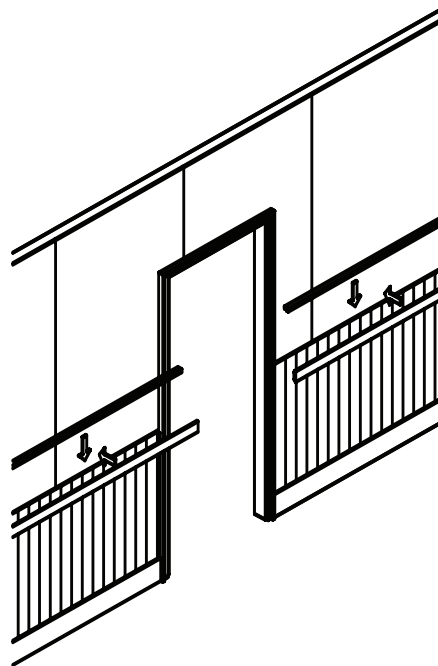

Clean-up, Care & Maintenance

Use mineral spirits to clean up excessive adhesive.

Plank/Panels & Wood Moldings are easily cleaned using a soft cloth and mild soap solution. Do not spray directly on the panel, rather dampen a soft cloth and wipe the panels.

Marlite Aluminum Trim

M-451 Inside Corner



M-465 Division



M-460 Outside Corner



M-453 135° Outside Corner



M-452 135° Inside Corner



M-470 Edge



Marlite Wood Molding

WG 474 Chair Rail



WG 475 Chair Rail



WG 477 Chair Rail



WG 1261 Base



WG 1647 I/C-O/C Corner



WG 2620 Edge



WG 946 Combination

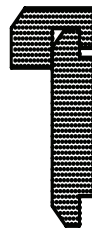

CAUTION!

PLEASE READ THIS!

Slight, natural-appearing color variations are a characteristic of this product, and are not manufacturing defects. To achieve the most pleasing appearance, the manufacturer recommends arranging planks on each wall to achieve the best combination of color before installing. Marlite will not honor claims arising from failure to comply.



Dover, Ohio 44622 • 330-343-6621
www.marlite.com • info@marlite.com

Form No. PK44-02121
Effective Date 11.1.2023
Copyright 2020